

CMOS Cascode Transconductance Amplifier

- Basic topology.

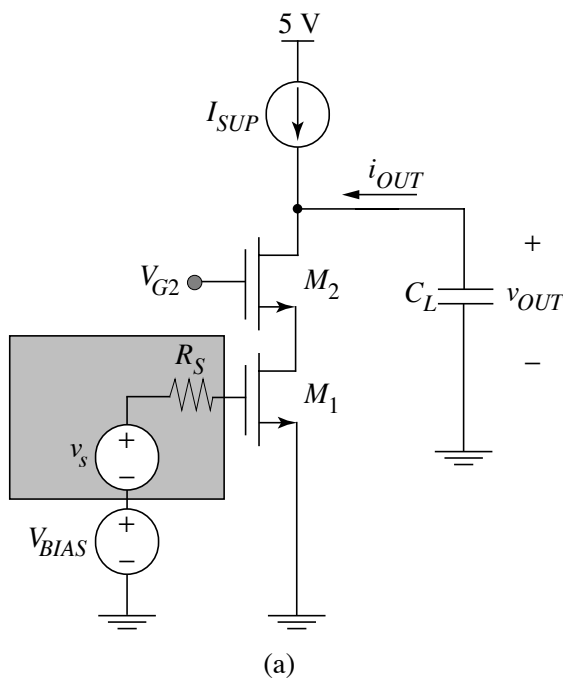

Device Data

$$V_{Tn} = 1 \text{ V } V_{Tp} = -1 \text{ V}$$

$$\mu_n C_{ox} = 50 \text{ } \mu\text{A/V}^2$$

$$\mu_p C_{ox} = 25 \text{ } \mu\text{A/V}^2$$

$$\lambda_n = 0.05 \text{ V}^{-1} \lambda_p = 0.02 \text{ V}^{-1} @ L = 2 \text{ } \mu\text{m}$$

(b)

- Current supply must have a very high source resistance r_{oc} since otherwise it will limit the output resistance of the amplifier

Current Supply Topology

- p-channel cascode current supply is a obvious solution

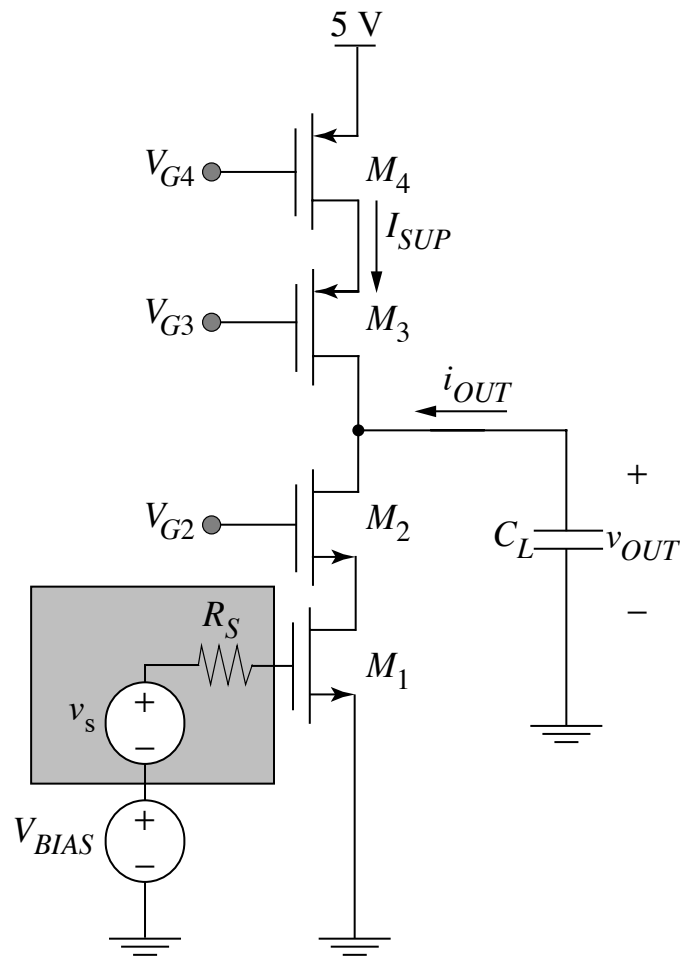

- need to design a totem pole voltage supply to generate V_{G2} , V_{G3} , and V_{G4}

Totem Pole Voltage Reference

- Match device sizes of M_{2B} , M_{3B} , and M_{4B} to M_2 , M_3 , and M_4

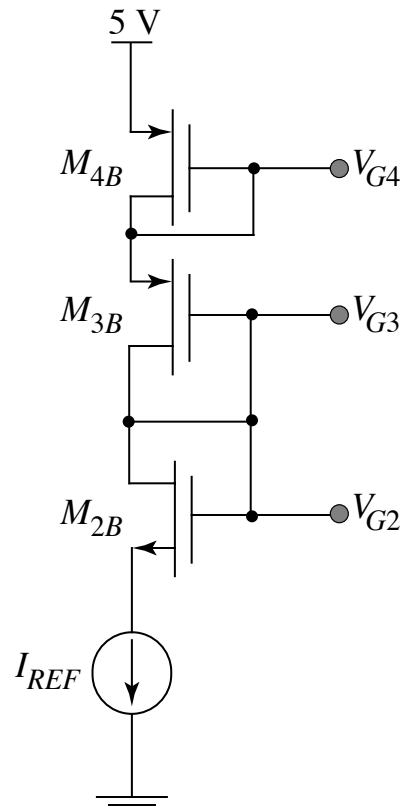

Complete Transconductance Amplifier

- V_{BIAS} : user must supply a *very* precise DC voltage $V_{BIAS} \approx 1.2 \text{ V}$ so that the CS/CGcascode is biased so that it is in the high gain region

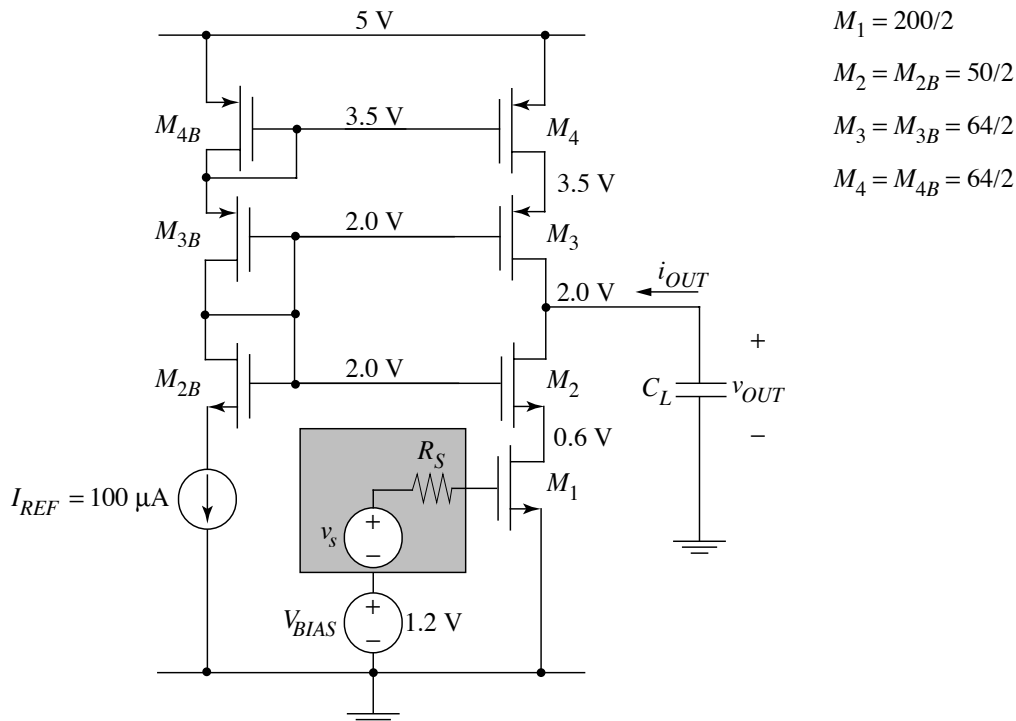

- Overall two-port parameters: $G_m = g_{m1}$

Output resistance: $R_{out} = r_{o2}(1 + g_{m2}r_{o1}) \parallel r_{o3}(1 + g_{m3}r_{o4})$

- Output swing:

$$V_{OUT(max)} = V_{D4} - V_{SD3(sat)} = V_{DD} - V_{SG4B} - V_{SG3B} + V_{SG3} - V_{SD3(sat)}$$

$$V_{OUT(max)} = 5 \text{ V} - 1.5 \text{ V} - 1.5 \text{ V} + 1.5 \text{ V} - 0.5 \text{ V} = 3.0 \text{ V}$$

$$V_{OUT(min)} = V_{D1} + V_{DS2(sat)} = V_{G2} - V_{GS2} + V_{DS2(sat)} = 2 \text{ V} - 1.4 \text{ V} + 0.4 \text{ V} = 1 \text{ V}$$

Multistage Voltage Amplifier

- Example to understand a complicated circuit

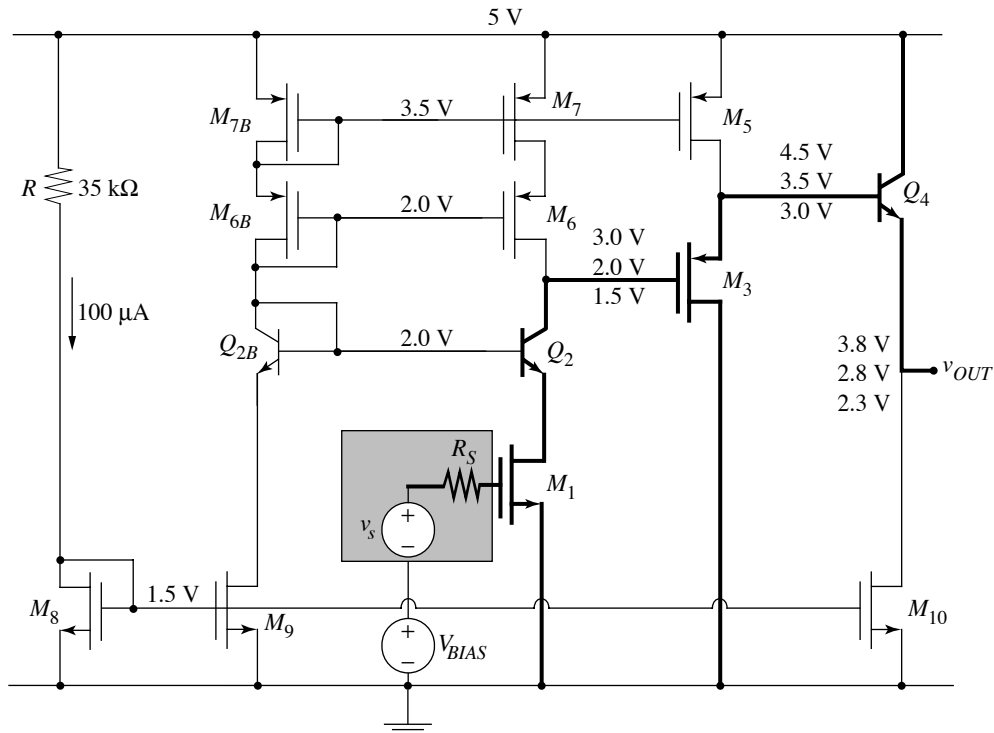

- 10 MOSFETs, 3 BJTs, 1 resistor ... must identify building blocks

Step-by-step approach to identifying the “important” transistors --

1. replace all transistor current sources and voltage sources by their symbols -- look for diodes and current mirrors! (M_5 , M_6/M_{6B} , M_7/M_{7B} , and M_{10} and Q_{2B} are part of current sources or a totem pole voltage reference.)
2. for the (few) remaining transistors, identify the type and use two-port small-signal models to understand the circuit’s operation. (For the above amplifier, the remaining transistors are M_1 , Q_2 , M_3 , and Q_4 .)

Eliminating Current and Voltage Sources

- Replace current and voltage sources with symbols

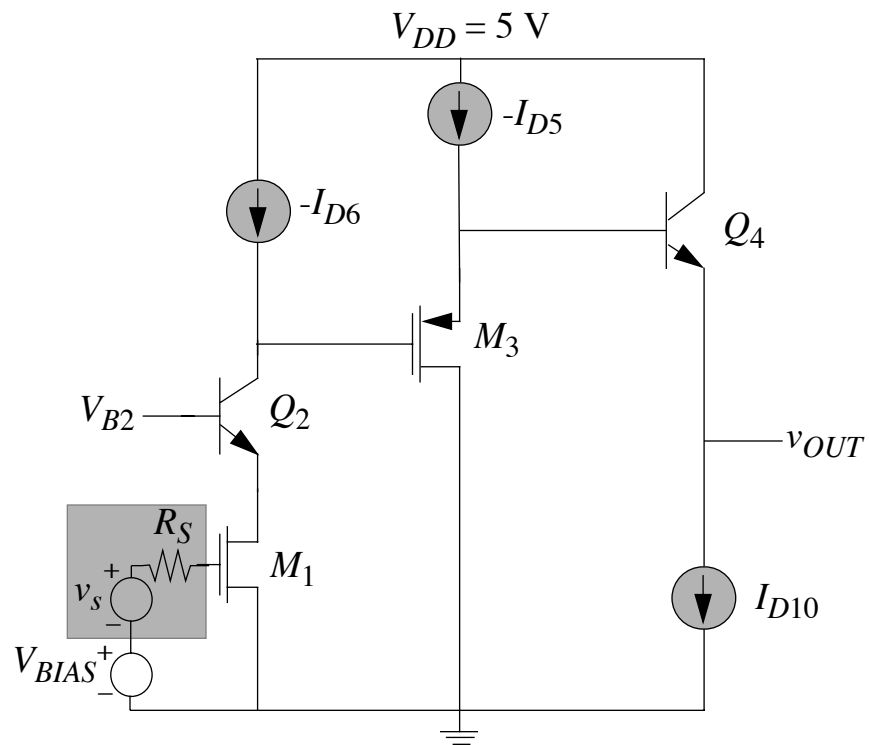

Identifying Amplifier Stages

- n-channel MOSFET M_1 has its source grounded --> common source
- npn BJT Q_2 has its gate tied to a voltage source (from “totem pole” string of diode-connected transistors) --> common base
- p-channel MOSFET M_3 has its drain connected to ground --> common drain
- npn BJT Q_4 has its collector tied to the positive supply --> common collector

Voltage amplifier is a cascade of two-port models:

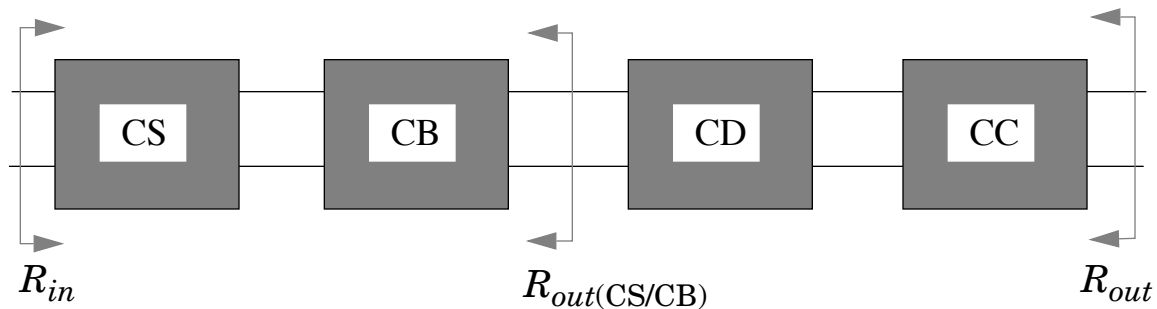

1. common source/common base with cascoded current-source supply: very high output resistance $R_{out(CS/CB)}$ --> can get extremely high output resistance, with a transconductance equal to that of the CS stage
2. common drain: no loading on previous stage since infinite input resistance
3. common collector: low output resistance

Cascode Stage Output Resistance

- Cascode input stage output resistance determines gain

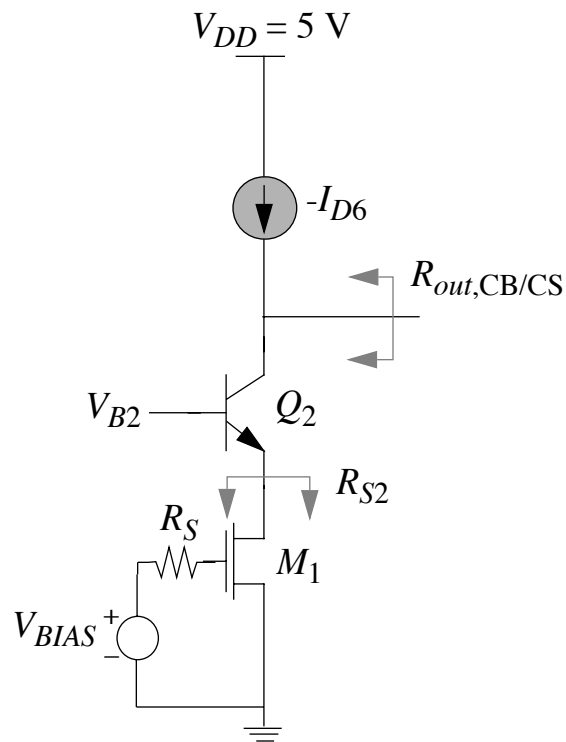

- Output resistance: note that $R_{S2} = r_{o1} \gg r_{\pi 2}$

$$R_{out,CB} = (\beta_{o2} r_{o2}) \parallel r_{oc6} = (\beta_o r_{o2}) \parallel (r_{o6} (1 + g_{m6} r_{o7}))$$

Overall Two-Port Parameters

- Since CC and CD stages have unity gain (approximately), we can quickly estimate the voltage gain by finding v_{in3}/v_{in} where v_{in3} is the input to the CD stage
- Voltage gain:

$$A_v \approx (-g_{m1})R_{out,CB} = -g_{m1}((\beta_o r_{o2}) || (r_{o6}(1 + g_{m6}r_{o7})))$$

- Output resistance: source resistance of CC output stage is relatively small, since it preceded by a CD stage.

$$R_{out} = R_{out,CC} \approx \frac{1}{g_{m4}} + \frac{R_{S,CC}}{\beta_{o4}} = \frac{1}{g_{m4}} + \frac{1}{g_{m3}\beta_{o4}}$$

DC Bias and Output Swing

- Assuming all n-channel devices have $V_{GS} = 1.5 \text{ V}$ and p-channel devices have $V_{SG} = 1.5 \text{ V}$, we can find all the node voltages ... we also assume that V_{BIAS} has been adjusted such that the circuit is in the high-gain region

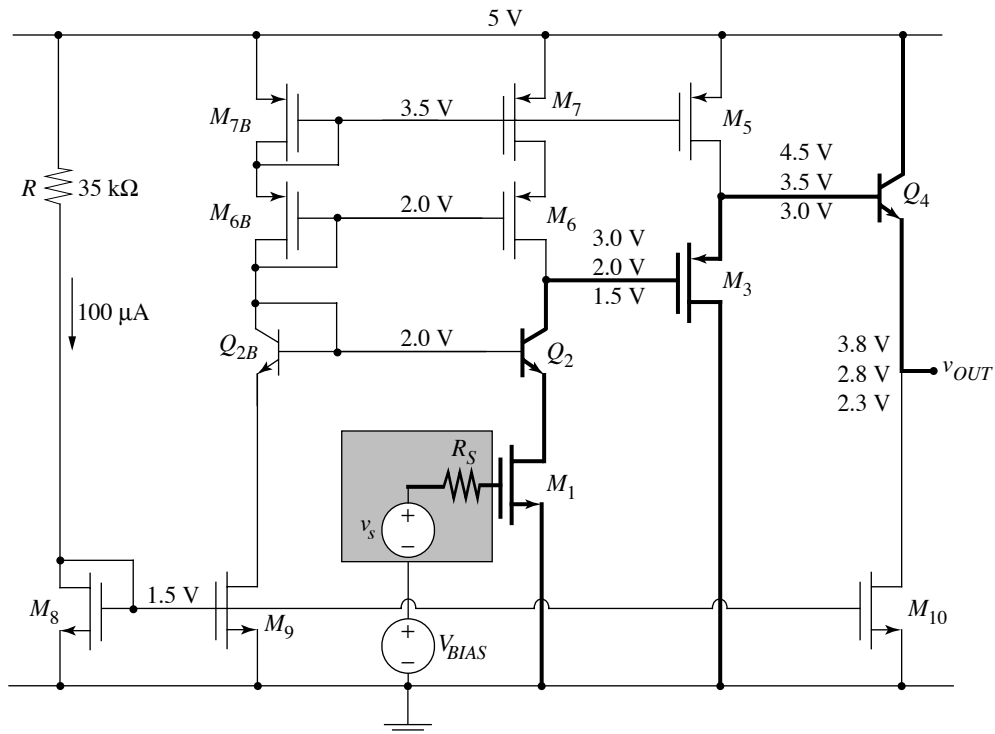

- Output swing: must consider more than output stage to find limits to V_{OUT}